

# MODEL 102

## MINI-PRO SLIDER BED CONVEYOR

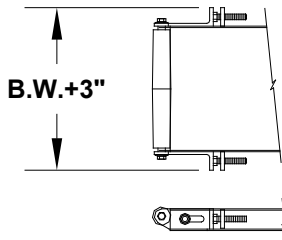

Optional Special Take-up

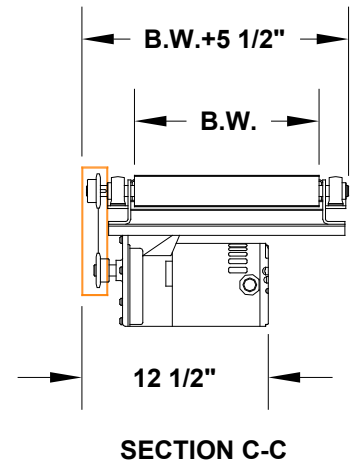
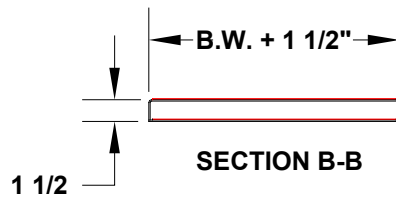
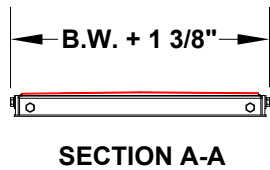
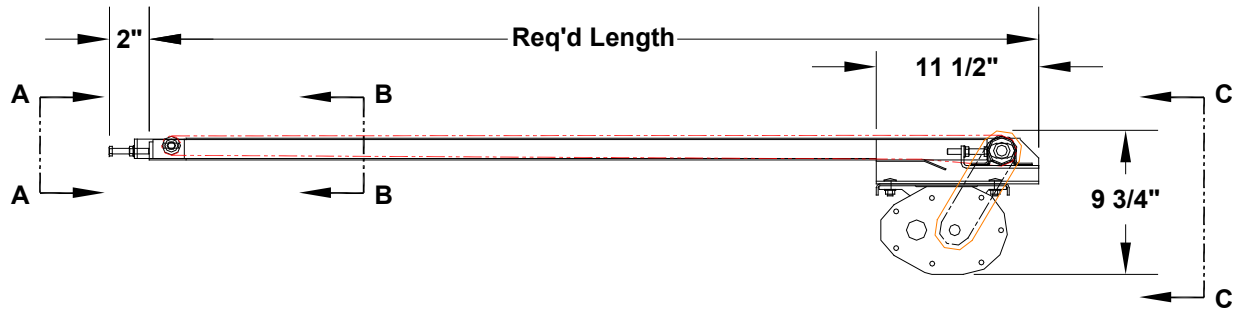
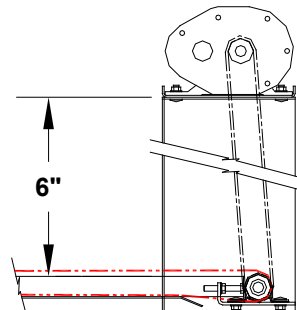

Optional Top Mount Drive

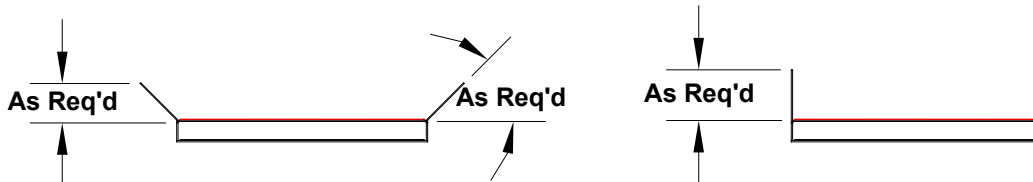

Optional Siderails



# MODEL 102

## MINI-PRO SLIDER BED CONVEYOR



Titan Industries has developed the **Model 102 MINI-PRO Press Conveyor** to solve scrap handling problems from under your dies. The MINI-PRO has a 1 1/2" low profile frame that will easily fit under most die parallels to quickly remove scrap or finished parts. A KNURLED 2" diameter drive pulley provides positive belt pull under extremely oily conditions. MINI-PRO's narrow frame width (belt width plus 1/2") is unique for this type of conveyor. A bottom mounted drive is furnished as standard but a top mounted drive arrangement is optional. Other optional features available are vertical or flared siderails to suit your application, supports as required, different belt types and special belt speeds. Standard belt widths from 2" to 24" wide, with lengths from 2' to 10' maximum as standard.

MODEL 102 SLIDER BED CONVEYORS SPECIFICATIONS		
	STANDARD	OPTIONS
<b>Belt Widths</b>	4", 6", 8", 12", 18", 24"	2", 10", 14", 16", 20"
<b>Lengths</b>	2' to 10'	3' to 10'
<b>Belt Type</b>	PVC 50 Black	Food Grade or belt to suit application
<b>Drive</b>	1/4 HP 115/1/60 Gearmotor	1/2 HP 230/460/3/60 TEFC, severe duty, inverter duty, brake motor
<b>Drive Pulley</b>	2" dia. crowned, knurled	
<b>Frame</b>	1-1/2" deep formed 12 ga.	
OPTIONAL ENHANCEMENTS		
H.P., drive location, speed, fixed or variable speed, belt type, siderails, supports, casters, side take-up, special paint, belt scraper, food grade, Many other options available, consult factory representative		

**NOTE: Specifications subject to change without notice**