

# MODEL 114

## TROUGHED BELT CONVEYOR

### STANDARD END DRIVE

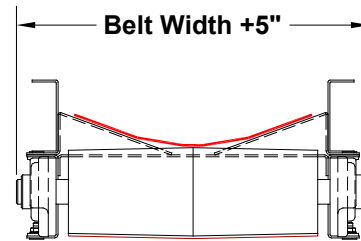
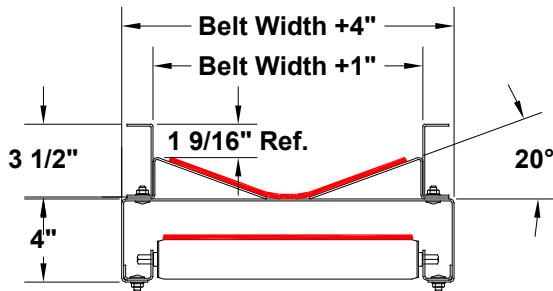
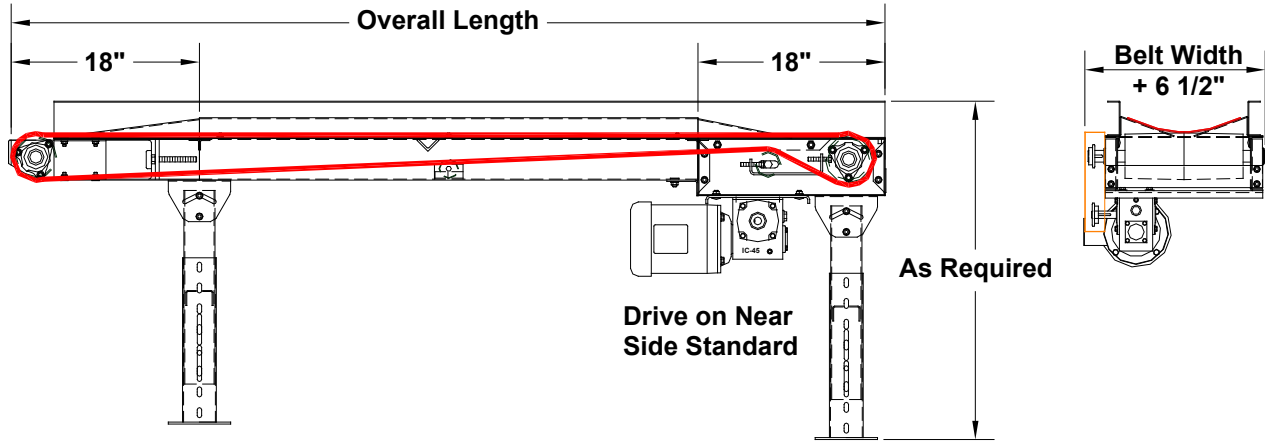

### STANDARD CENTER DRIVE & TAKE-UP

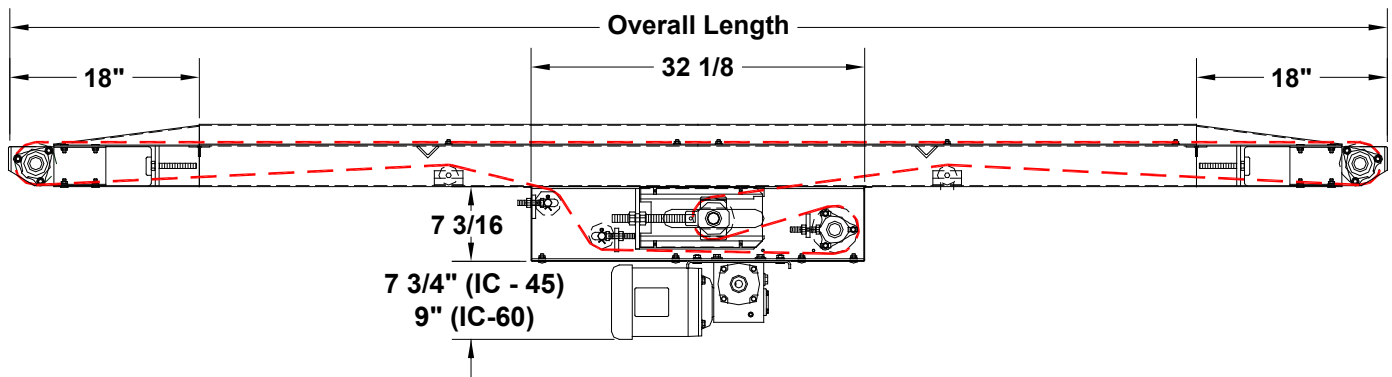

# MODEL 114 TROUGHED BELT CONVEYOR

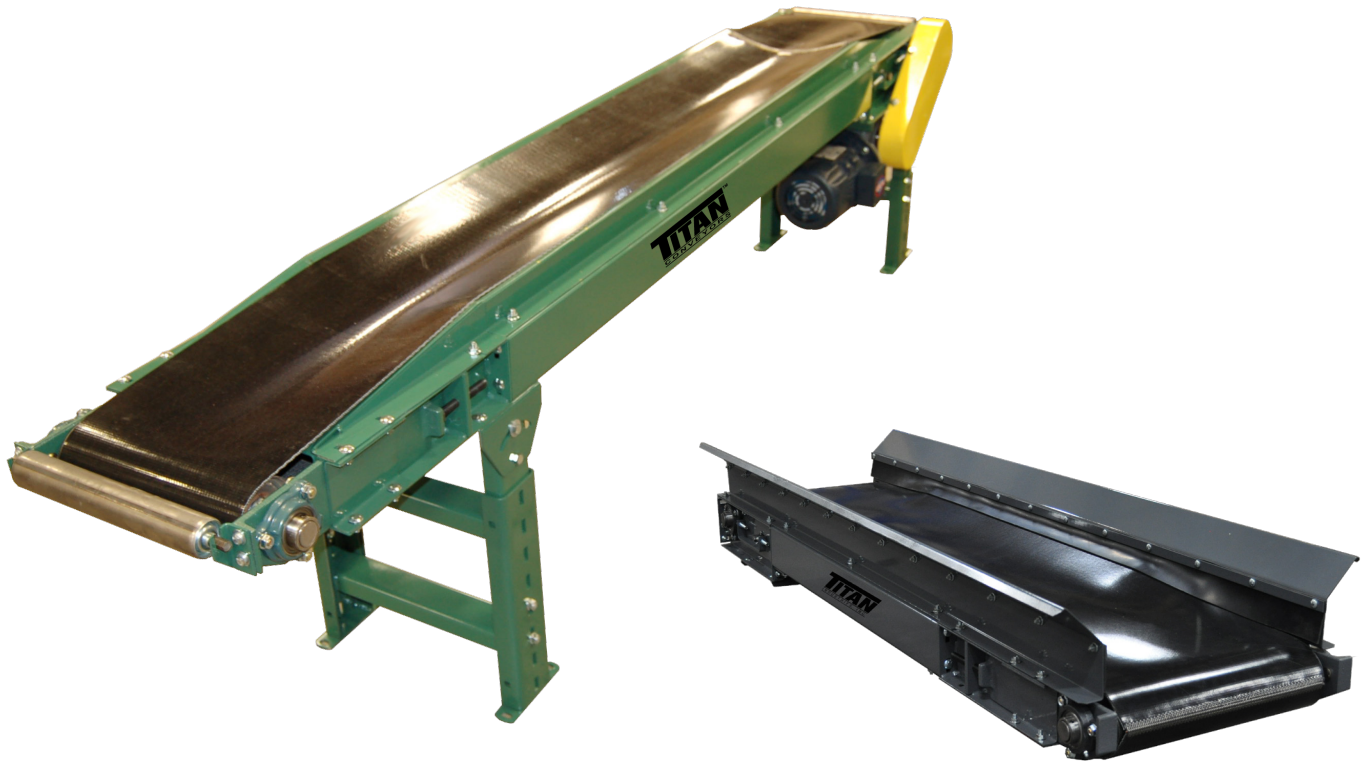

The **Model 114 troughed belt conveyor** is designed with simplicity & flexibility in mind. The standard 4" deep formed 12 gauge frame allows for reduced total weight and yet the rigidity needed for lighter duty applications. Excellent design for transporting loose parts or bulk materials. Bottom, top or center drive available.

MODEL 114 SLIDER BED TROUGH CONVEYORS		
	Standard	Options
<b>Belt Widths</b>	12", 18", 24", 30", 36"	8", 14", 16", 20", 40"
<b>Lengths</b>	5' min. to 40' max.	3' min. to 40' max.
<b>Belt Type</b>	PVC 120 Black	Food grade
<b>Drive</b>	1/2 H.P. 230/460/3/60	3/4, 1, 1-1/2, 2 HP, 115/230/1/60, TEFC, washdown, severe duty, inverter duty, brake motor
<b>Drive Pulley</b>	4" dia. crowned rubber lagged - 4" tail pulley	
<b>Frame</b>	4" deep formed 12 g.a.	
<b>OPTIONAL</b>		
H.P., drive location, speed, fixed or variable speed, controls, belt widths, belt type, center drive & take-up, galvanized, stainless, siderails, supports, casters, other belt types, siderail skirting, belt scrapper, machined and balanced pulleys for high speed, discharge housing, e-stop with pull cord, special paint		
Many other options available, consult factory representative		

**NOTE: Specifications subject to change without notice**