

MODEL 118

TROUGHED BELT CONVEYOR

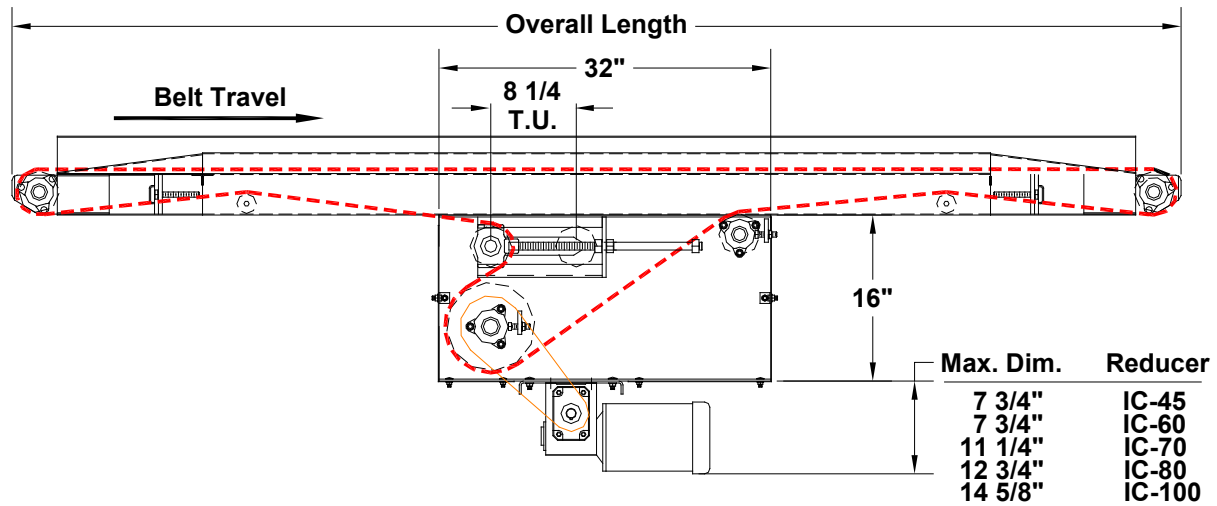

Standard Center Drive & Take-Up

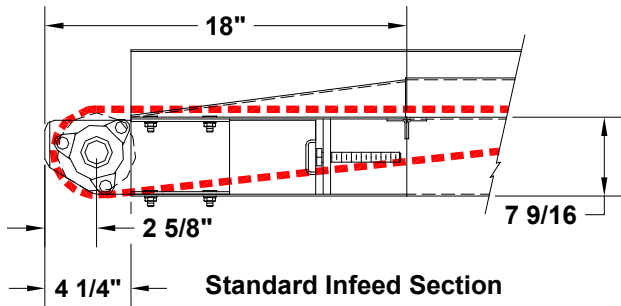

Standard Infeed Section

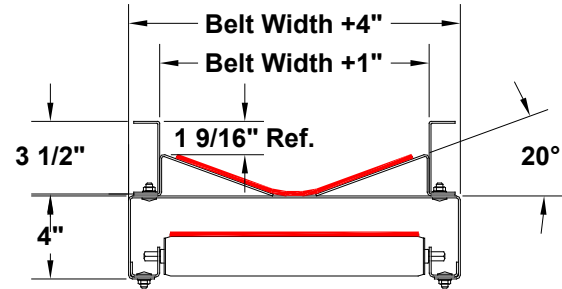

Standard Frame Cross Section

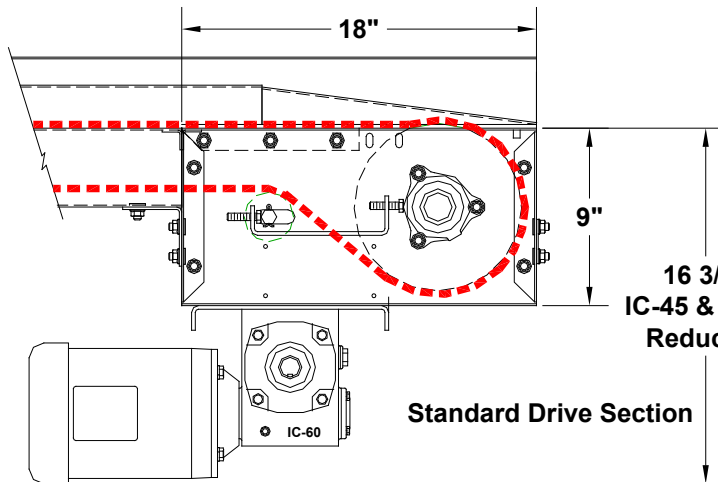

Standard Drive Section

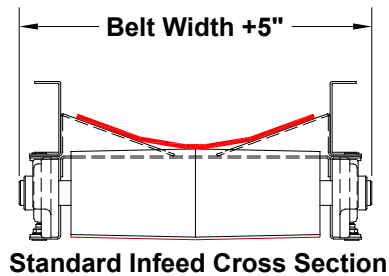

Standard Infeed Cross Section

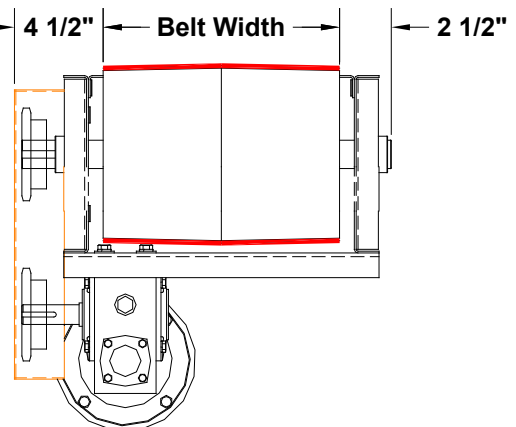

Standard Drive Cross Section





MODEL 118
TROUGHED BELT CONVEYOR



The Model 118 troughed belt conveyor is designed as a cost competitive medium duty bulk conveyor. The standard 4" deep formed 12 gauge frame allows for reduced total weight and yet the rigidity needed for medium duty applications. Excellent design for transporting loose parts or bulk materials. Bottom, top or center drive available.

MODEL 118
SPECIFICATIONS

DRIVE:.....	1/2 H.P. 230/460/3/60
BELT SPEED:.....	60 F.P.M.
BELT:	Black PVC
FRAME:	4" Deep Formed 12 Gauge
PULLEYS:	8" Diameter Crown Face Rubber Lagged Drive 4" Diameter Crown Face Take-up
SUPPORTS:.....	"H" Type Adjustable For 30" Elevation
PAINT:.....	One Coat Industrial Enamel

NOTE: Specifications subject to change without notice