

POWERED TURNTABLE

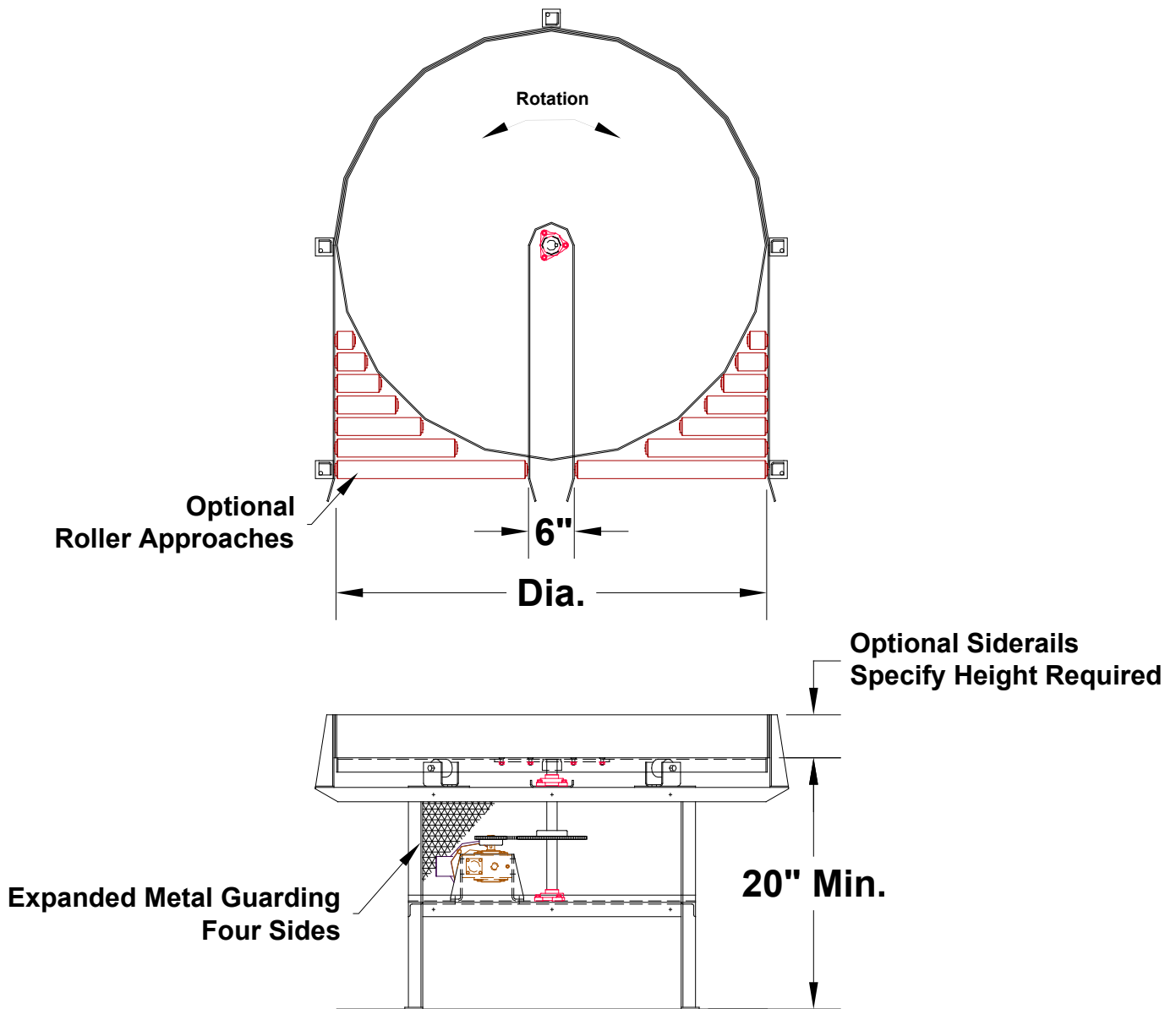

735 Industrial Loop Road • New London, WI 54961-9612 • (920-982-6600 • Fax (920-982-7750 * Toll Free 800-558-3616
Website: www.titanconveyors.com Email: sales@titanconveyors.com

POWER TURNTABLE

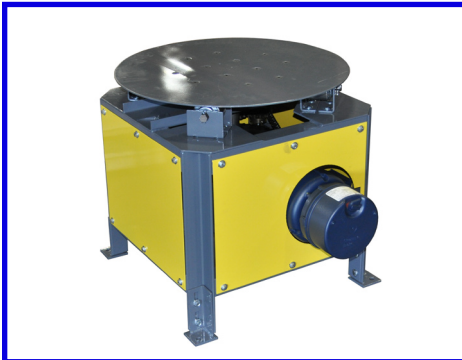

When your plant layout requires a directional change in the smallest possible space, you should consider using a **Titan Powered Turntable**. The turntable can be used for product sortation, accumulation as well as directional changes. The Titan Turntable is available in sizes ranging from 2' diameter to 10' diameter. The standard table top is 7 gauge construction with angle iron supports. The top is driven by either chain and sprockets or a contact wheel. The unit is furnished with expanded metal guards on all four sides. Roller supports supplied as optional equipment. The unit can be supplied with chain and sprocket drive, air operated for 90° rotation or no drive for manual indexing. Tops can be fitted with gravity roller or chain driven live roller conveyor to suit your application.

MODEL 200 TURNTABLE SPECIFICATIONS		
	Standard	Options
Diameter	Customer can specify	
Drive	1/2 H.P. 230/460/3/60	1, 1-1/2, 2 HP, 115/230/1/60 Severe duty, inverter duty, brake motor
Table Top	7 gauge	Others available
Drive Location	Bottom mount drive	
Speed	2.5 RPM fixed	Fixed speeds - specify, variable speed with DC motor & SCR controller or AC inverter
OPTIONS		
H.P., variable speed, controls, siderails, air operated, conveyor on top, roller or skate wheel approaches, galvanized, stainless, special paint		
Many other options available - consult factory		

NOTE: Specifications subject to change without notice