

MODEL 310

PARTS CONVEYOR

Optional Infeed Hopper

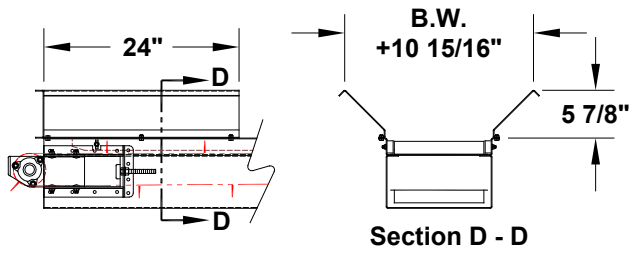

Optional Top Mount Drive

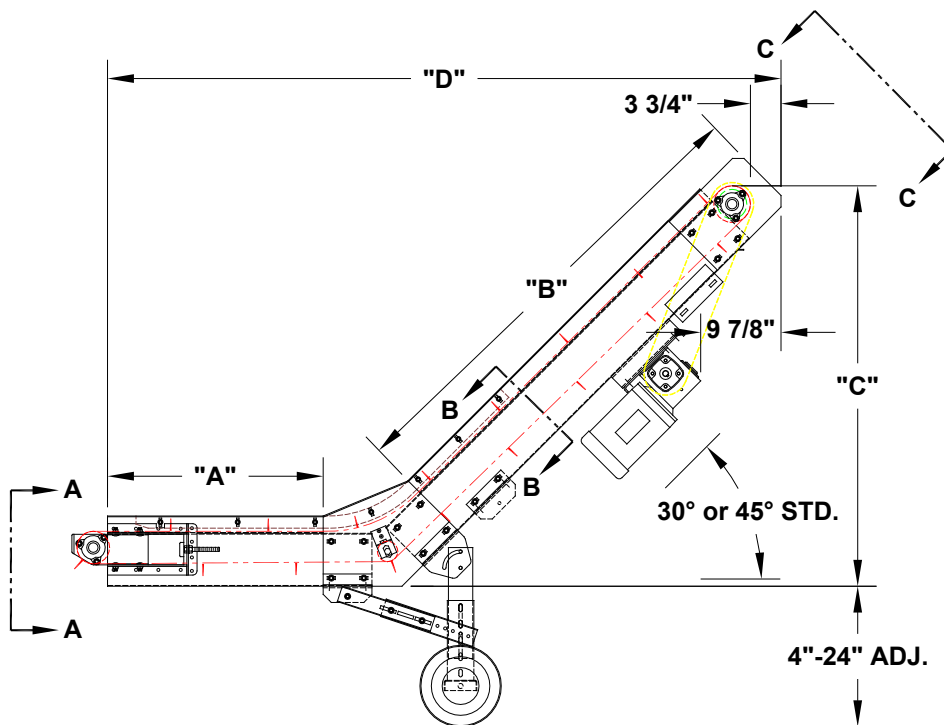
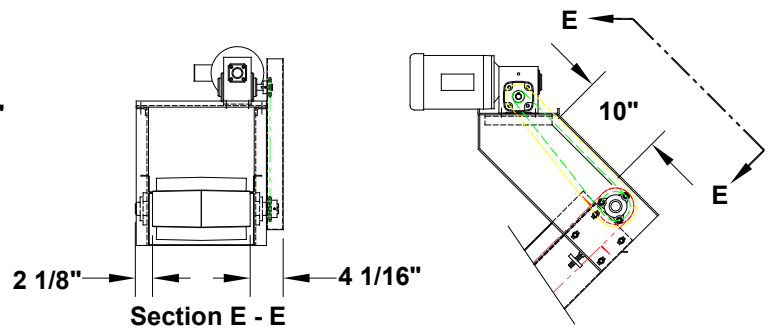

		"D" O.A.L.			
		30°			
"A" INFEED		"B" (Incline)			
		36"	48"	60"	72"
24"		71	81.5	92	102.5
36"		83	93.5	104	114.5
48"		95	105.5	116	126.5
60"		107	117.5	128	138.5
"C" Hgt.		26	32	38	44

		"D" O.A.L.			
		45°			
"A" INFEED		"B" (Incline)			
		36"	48"	60"	72"
24"		65.5	74	82.5	91
36"		77.5	86	94.5	103
48"		89.5	98	106.5	115
60"		101.5	110	118.5	127
"C" Hgt.		34.7	43.2	51.7	60.2

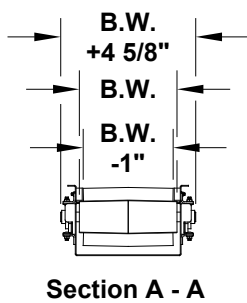

Section A - A

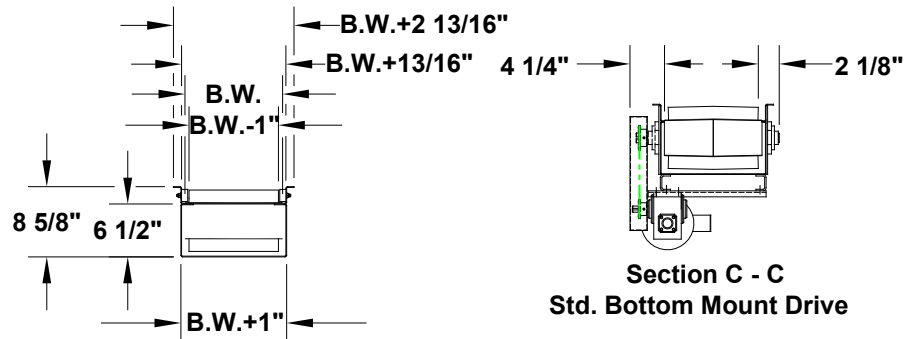

Section B - B

Section C - C
Std. Bottom Mount Drive



735 Industrial Loop Road • New London, WI 54961-9612 • 920-982-6600 • Fax 920-982-7750 • Toll Free 800-558-3616

Website: www.titanconveyors.com • Email: sales@titanconveyors.com

