

MODEL 340 SIDEWALL CONVEYOR

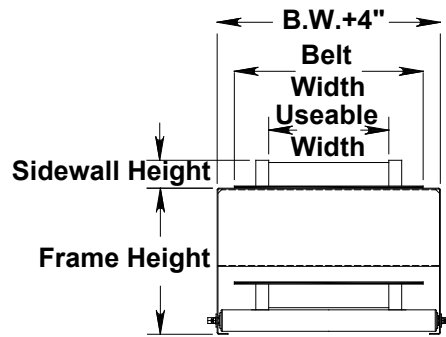

Section C-C

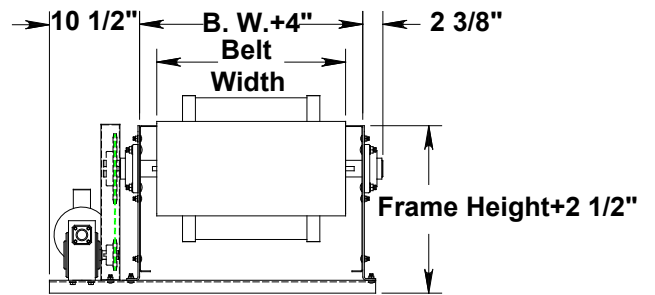

Section D-D

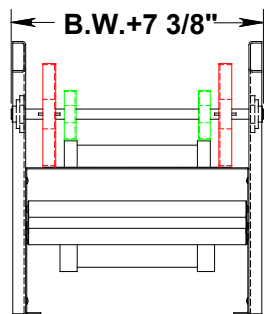

Section B-B

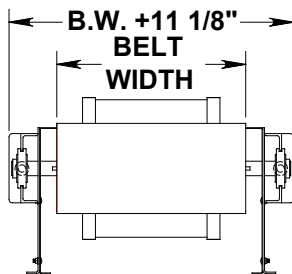

Section A-A

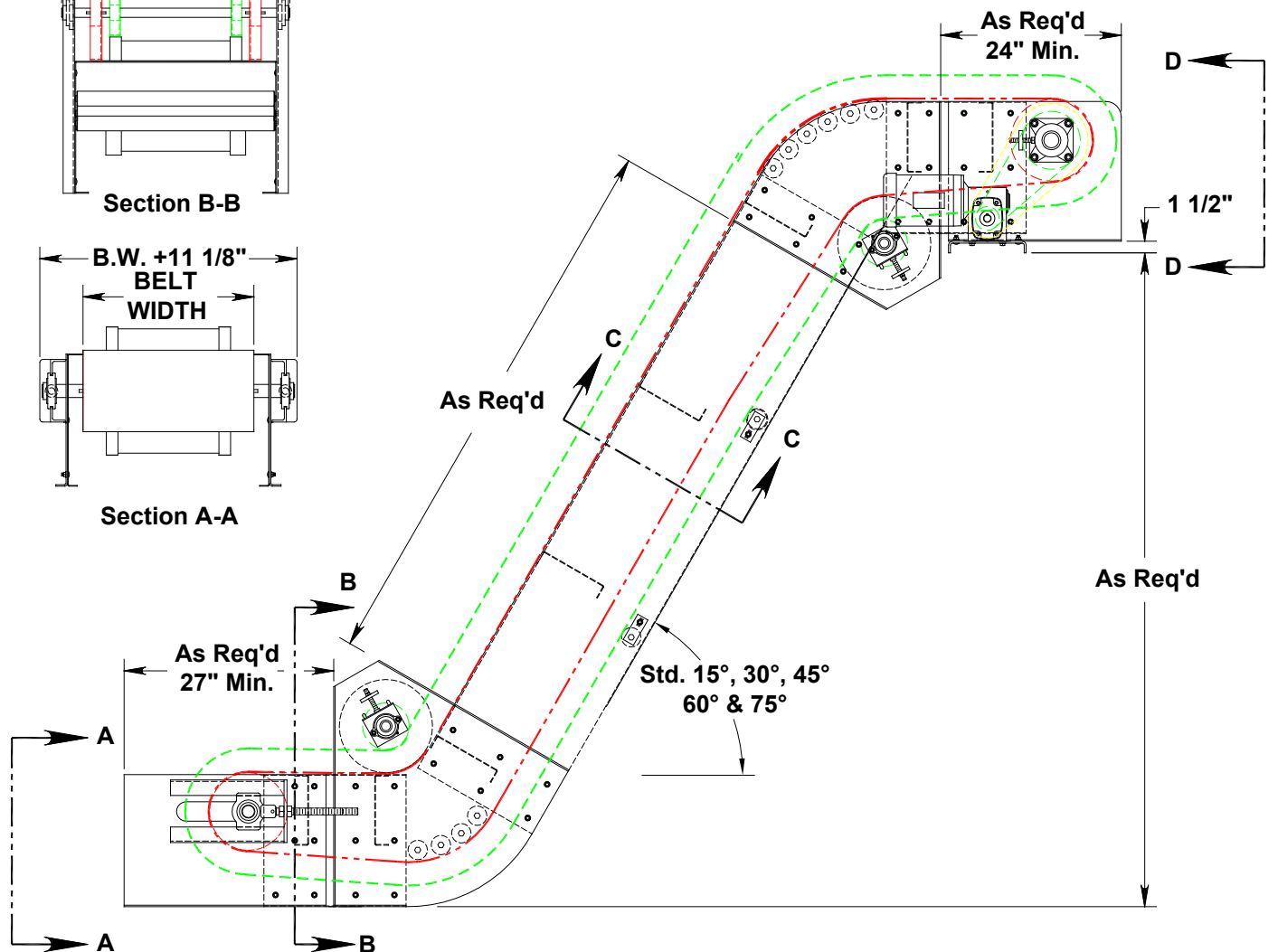

735 Industrial Loop Road • New London, WI 54961-9612 • 920-982-6600 • Fax 920-982-7750 • Toll Free 800-558-3616

Website: www.titanconveyors.com • Email: sales@titanconveyors.com

TITANTM

INDUSTRIES, INC.

MODEL 340 SIDEWALL CONVEYOR



When your application calls for a conveyor that requires a horizontal section, incline section, horizontal configuration and a steel belt cannot be used, then turn to the Titan Model 340 Sidewall Conveyor. This unit can also be supplied in other configurations. The sidewall belt is used for handling a wide variety of material from bulk powders to parts to an abrasive lumpy material. Standard construction is mild steel but stainless steel construction and white belts are available for handling food products. The unit is available in various belt widths, angles of incline, lengths of straight sections and numerous sidewall heights, cleat heights and cleat centers. Further details and quotations supplied upon request.

MODEL 340 SPECIFICATIONS

DRIVE:..... Sized Per Application
BELT SPEED:..... 60 F.P.M.
BELT: Consult Factory
FRAME: Formed 12 gauge
PULLEYS: Diameter Determined by Belt Specifications
SUPPORTS: Structural Channel
PAINT:..... One Coat Industrial Enamel

NOTE: Specifications subject to change without notice