

# MODEL 404

## BELT-DRIVEN LIVE ROLLER

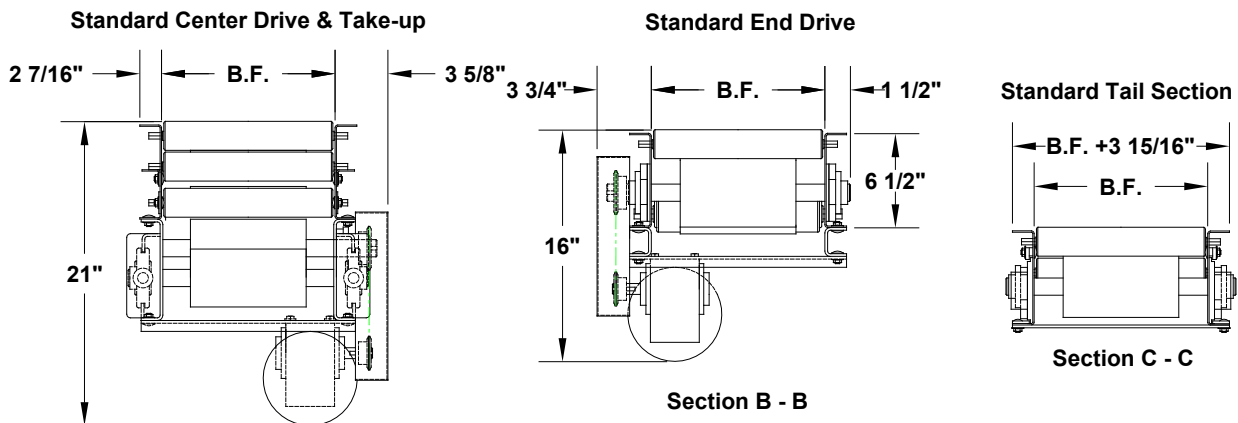
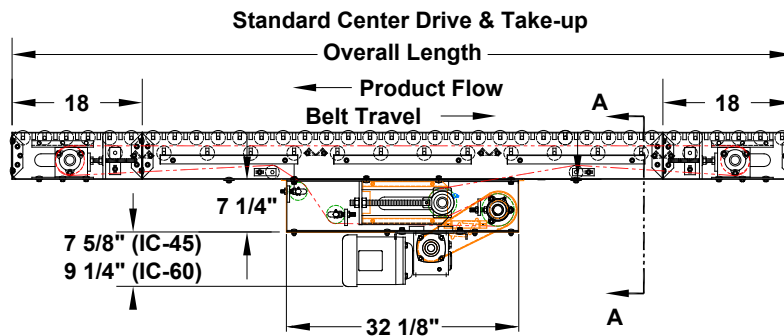
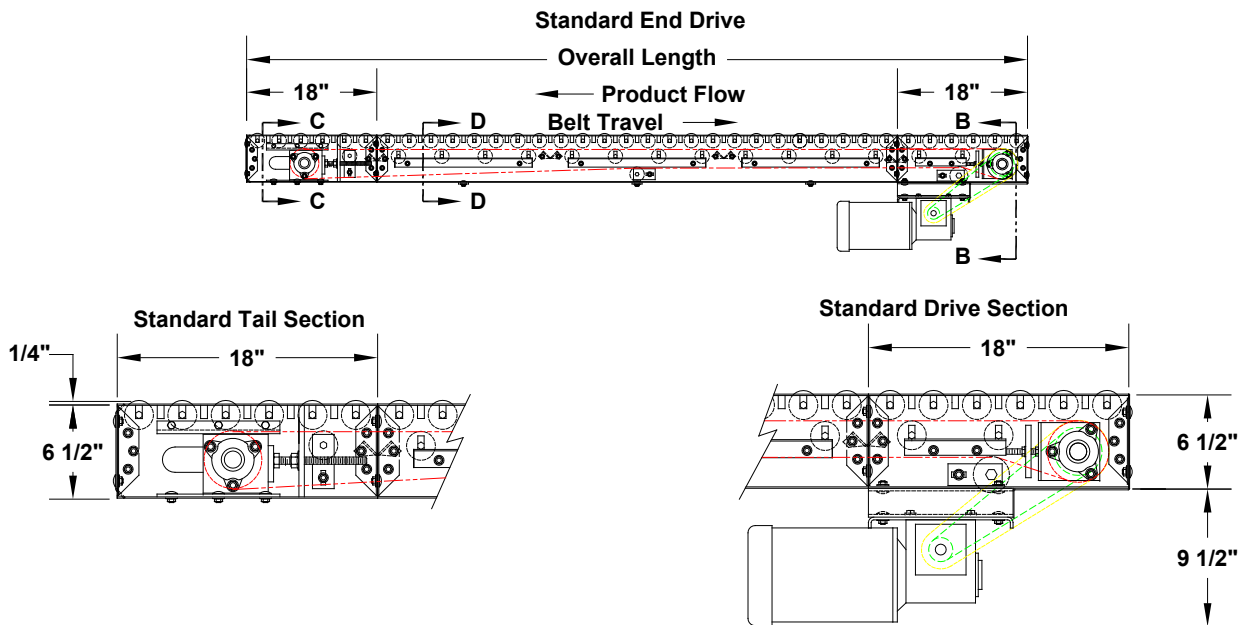

Section A - A

Section B - B

Section C - C

Standard Intermediate Frame

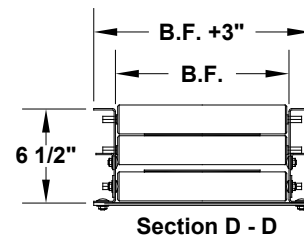



**MODEL 404**  
**BELT-DRIVEN LIVE ROLLER CONVEYOR**



The Titan Model 404 Belt-Driven Live Roller Conveyor features all of the time proven design features that you've come to expect from Titan. Standard Features include 4" diameter drive and tail pulleys, grease sealed industrial 3 bolt flange bearings, heavy duty formed 12 gauge frame and a P.V.C. drive belt. The Model 404 uses 1.9 diameter x 16 gauge rollers with 7/16" spring loaded hex shaft and grease-packed bearings. Standard roller centers are 6" with optional 3" and 4 1/2" centers. Compression rollers are also 1.9 x 16 gauge and mounted on 6" centers. Standard between frame widths start at 13" and range to 41".

**MODEL 404**  
**SPECIFICATIONS**

DRIVE:.....1/2 H.P. 230/460/3/60  
ROLLERS:..... 1.9" Diameter x 116 gauge  
SPEED: ..... 60 F.P.M.  
FRAME: ..... Formed 12 Gauge  
PULLEYS: .....4" Diameter Crown Face Rubber Lagged Drive  
4" Diameter Crown Face Take-up  
BEARINGS:..... Grease Sealed  
SUPPORTS:..... "H" Type Adjustable  
PAINT:..... One Coat Industrial Enamel

**NOTE: Specifications subject to change without notice**