

MODEL 610

HINGED STEEL BELT CONVEYOR

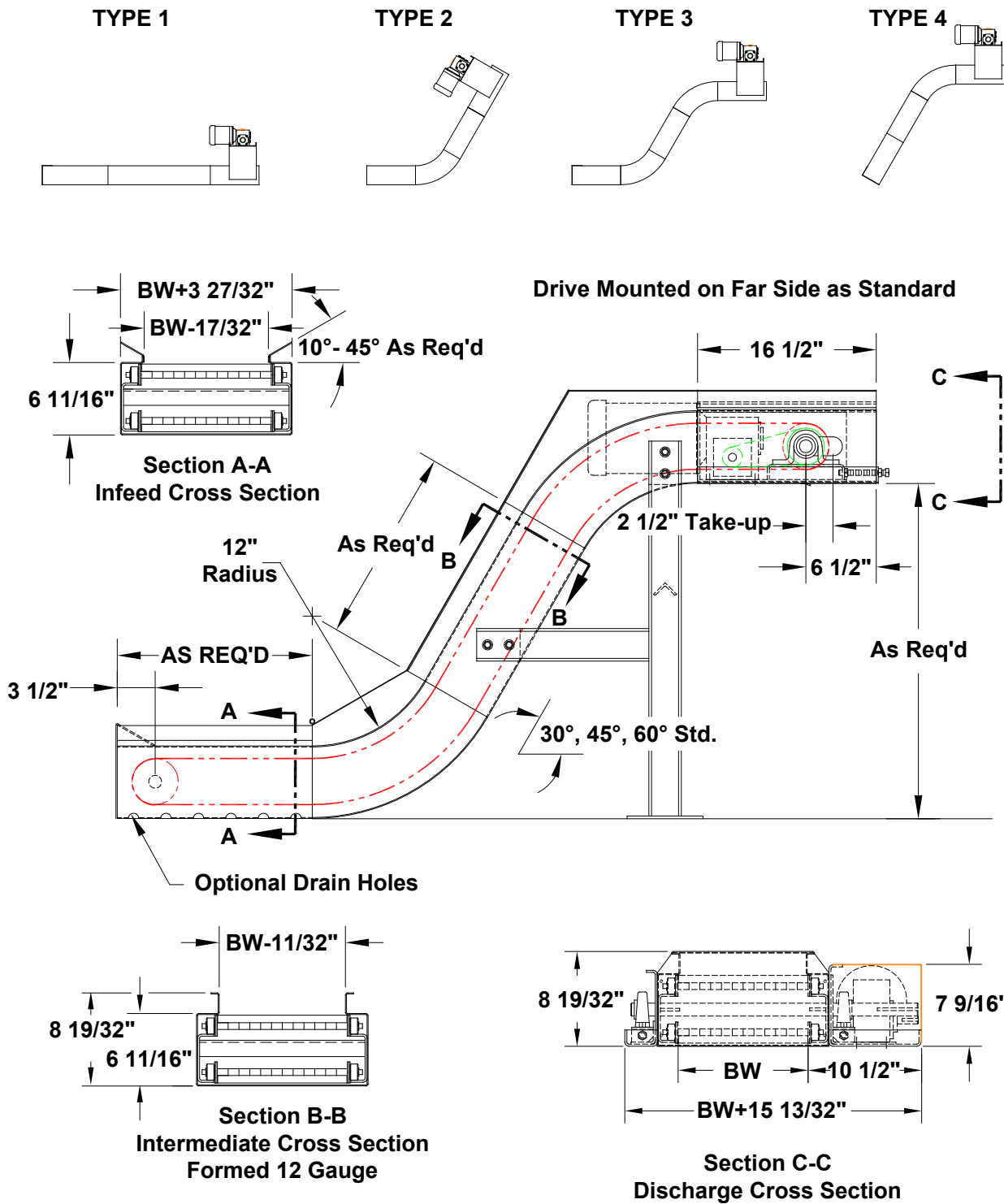

735 Industrial Loop Road • New London, WI 54961-9612 • 920-982-6600 • Fax 920-982-7750 • (Outside Wisconsin) 800-558-3616

Website: www.titanconveyors.com • Email: sales@titanconveyors.com



MODEL 610
HINGED STEEL BELT CONVEYOR



The Titan Model 610 Chip Conveyor fits the needs of today’s machine tool environment. Starting with the low profile 12 gauge frame (6-11/16” deep) this unit is designed for rugged chip handling applications. Standard features include flared infeed siderails, liquid tight bottom pan, 2” high vertical siderails with bolt on top cover and chip suppressor, bushed sprockets on the infeed and low profile side mount drive. Belt widths are available from 6” to 30” with plain, perforated or pimped belt styles available. The 10 F.P.M. belt speed allows for adequate coolant drainage. The Model 610 features the exclusive Titan powdered metal siding that virtually eliminates any gap between the sidewings and aprons, thus reducing jamming problems. The unit shown above has optional drain holes on the infeed and an optional right hand drive.

MODEL 610
SPECIFICATIONS

DRIVE:.....	1/2 H.P. 230/460/3/60
SPEED:	10 F.P.M.
FRAME:	Formed 12 Gauge
SPROCKETS:	5 Tooth, 4.25” P.D.
BEARINGS:.....	Grease Sealed-Drive End Marine Bushings-Infeed End
SUPPORTS:.....	Structural Channel
PAINT:.....	One Coat Industrial Enamel

NOTE: Specifications subject to change without notice