

MODEL 680

2-STRAND CHAIN CONVEYOR

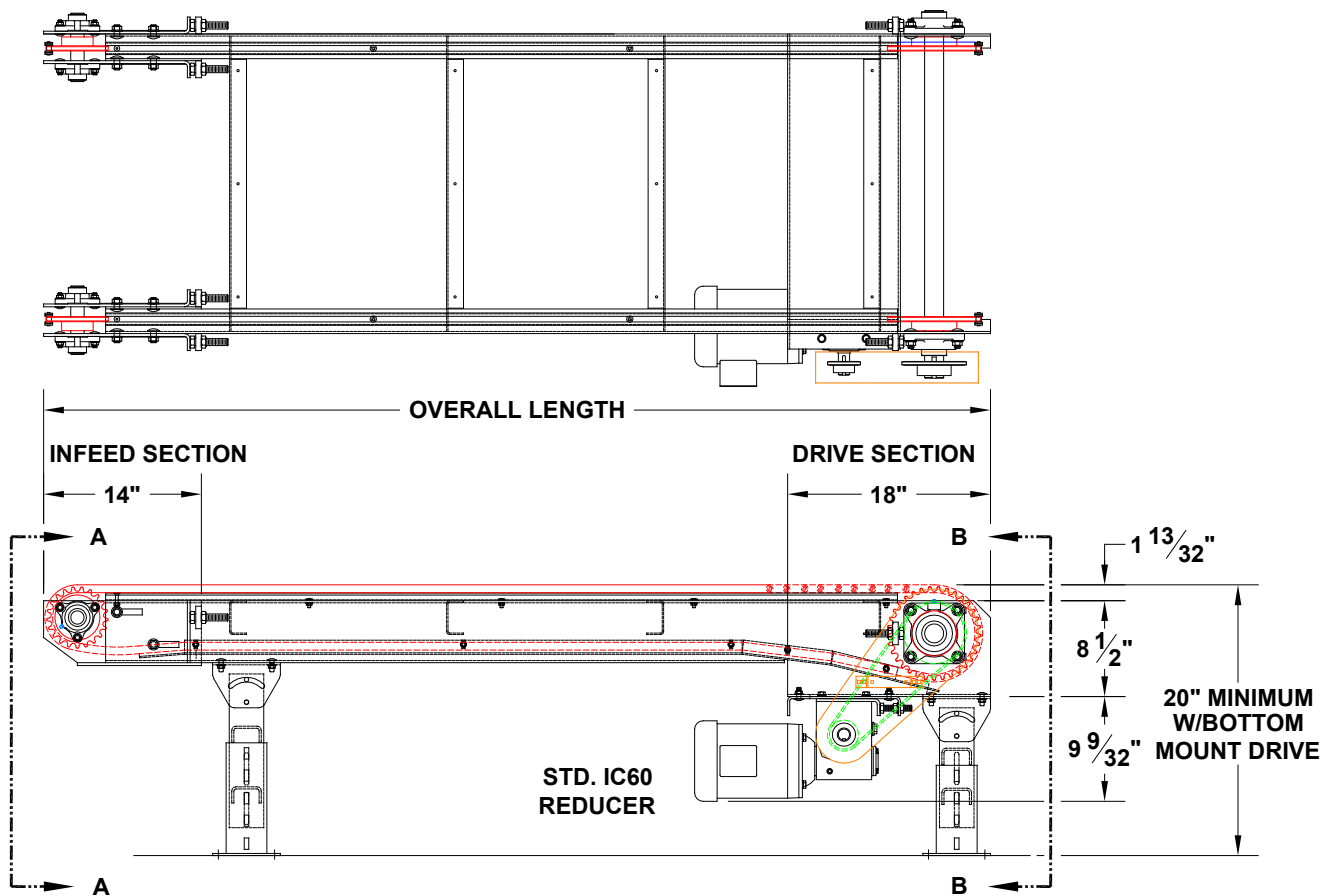
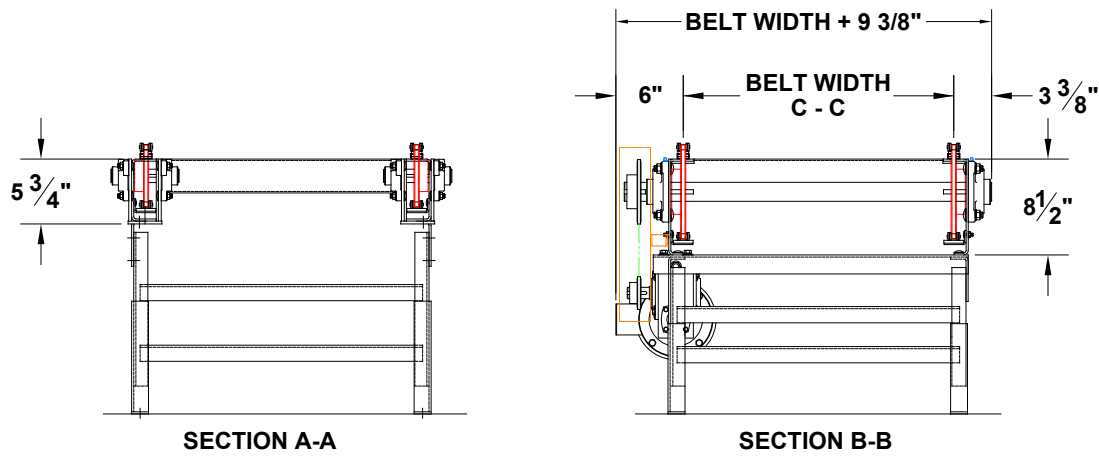

735 Industrial Loop Road • New London, WI 54961-9612 • 920-982-6600 • Fax 920-982-7750 • Toll Free 800-558-3616

Website: www.titanconveyors.com • Email: sales@titanconveyors.com



MODEL 680
2-STRAND CHAIN CONVEYOR



The Model 680 2 strand chain conveyor is used to convey products that are not conveyable on a standard roller conveyor. The standard chain is C2060 double pitch with a load capacity of 2,400 lbs. An optional C2080 double pitch chain can be used for loads up to 4,000 lbs. Optional low profile side mounted drive and additional strands of chain can be added to increase load capacities.

MODEL 680 SPECIFICATIONS

DRIVE:.....	1 H.P. 230/460/3/60
CHAIN SPEED:	30 F.P.M.
FRAME:	Formed 7 Gauge
CHAIN:	(2) Strands of C2060 C2080 Optional
CAPACITY:	2,400 lbs. with (2) strands C2060 4,000 lbs. with (2) strands C2080
PAINT:.....	One Coat Industrial Enamel

NOTE: Specifications subject to change without notice