

TITANTM
CONVEYORS

Hinged Steel Belt Conveyors



RADIAL SIDEWINGS - A Titan Exclusive

Since 1981

The TITAN Experience -
Expect More

Designed for years of
maintenance free
operation in hostile
environments

Proven Reliability
Low Maintenance
Quick Delivery

735 Industrial Loop Road
New London, WI 54961-2600

Phone: (920) 982-6600

Fax: (920) 982-7750

Toll Free: 1-800-558-3616

Website: www.titanconveyors.com

Email: sales@titanconveyors.com

Model 610

- 2 1/2" pitch
- Exclusive radial sidewings
- Low profile frame
- Flared Infeed siderails
- Liquid tight bottom pan
- Chip suppressor
- Belt widths 4" to 24"

Medium duty designed for chips



Exclusive Titan radial sidewings eliminate the gaps that cause parts damage and material seepage.

Model 620

- 2 1/2" pitch
- Exclusive radial sidewings
- Low profile 10 ga. frame
- Custom siderails
- Belt widths 4" to 42"
- Optional hoppers, chutes, tanks & more

Heavy duty for chips, scrap and parts



Model 630

- 2 1/2" pitch
- Rugged 10 ga. formed frame
- 1 1/2" high stamped sidewings
- Custom siderails
- Belt widths 4" to 42"
- Optional hoppers, chutes, tanks & more

Extreme duty for larger scrap and parts

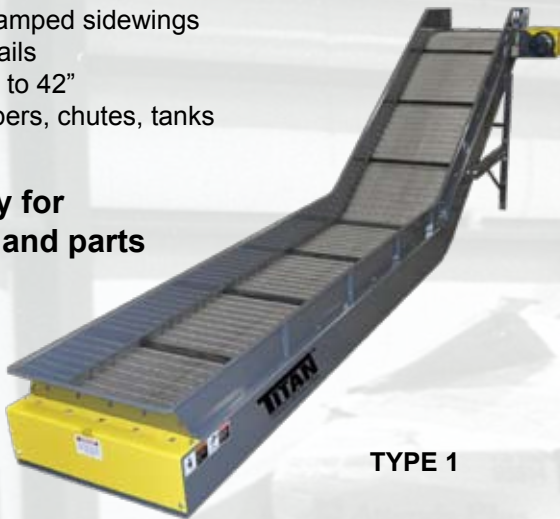

Profiles Available

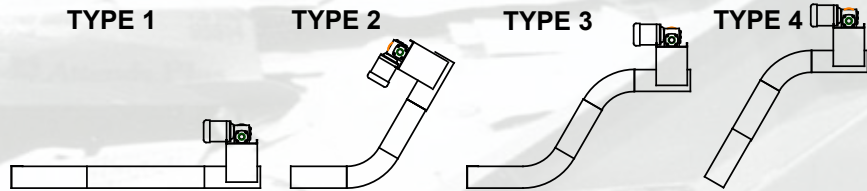

2-1/2" PITCH HINGED STEEL BELT MODELS			
	610	620	630
	Standard	Standard	Standard
Drive	1/2 H.P. 230/460/3/60	1/2 H.P. 230/460/3/60	1/2 H.P. 230/460/3/60
Belt Speed	10 F.P.M.	30 F.P.M.	30 F.P.M.
Frame	6-11/16" deep formed 12 ga.	7" deep formed 10 ga.	8-5/8" deep formed 10 ga.
Belt	2-1.2" pitch radial sidewing	2-1/2 pitch low profile or radial sidewing	2 1/2" pitch 1-1/2" standard stamped sidewing
Belt Width	4" to 24"	4" to 24"	4" to 24"
Supports	Structural steel	Structural steel	Structural steel
Curves	30°, 45°, 60°	30°, 45°, 60°	30°, 45°, 60°

OPTIONS

Drive location, H.P., fixed and variable speed, tanks, chutes, plumbing, top covers, chip suppressors, casters, liquid tight bottom pans, special paint, Belt: belt widths, pimpled, perforated, welded barrels, impact plates, wiper cleats, cleat heights, sidebars on narrower belts

Many other options available, consult factory representative

Model 640

- 4" pitch belt
- Exclusive radial sidewings
- 6000 lb. chain pull
- 2" dia. bushed flanged rollers
- 10 ga. formed frame
- 10 ga. belt



Model 660

- 6" pitch belt
- Exclusive radial sidewings
- 8,900 lb. pull capacity
- 3" dia., bushed, flanged rollers
- 7 ga. formed frame
- 1/4" belt

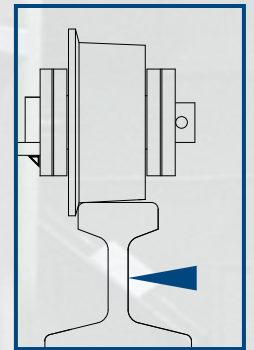

H.D. 25# rail track reduces wear factors and improves conveyor integrity



STANDARD SPECIFICATIONS

	Model 640 - 4" PITCH	Model 660 - 6" PITCH
Drive	1/2 H.P. 230/460/3/60	3/4 H.P. 230/460/3/60
Speed	30 F.P.M.	30 F.P.M.
Frame	15" deep formed 10 ga.	21" deep formed 7 ga.
Belt	4" pitch, 10 ga. apron	6" pitch x 1/4" apron
Belt Width	6" to 60"	12" to 72"
Supports	Structural Channel	Structural Channel
Curves	30°, 45°, 60°	30°, 45°, 60°

OPTIONS

Drive location, H.P., fixed and variable speed, impact rails on infeed frame, T-slot bearings, customized siderails, infeed hoppers, casters, liquid tight bottom pans, coolant tanks, plumbing.

Belt: belt widths, pimped, perforated, welded barrels, impact plates, wiper cleats, cleat heights

Consult factory for special applications and construction of belt.

Titan makes Hinged Steel Belt replacements for any manufacturer. Call factory for details, save money and time.

Radial Sidewings - a TITAN Exclusive

Close the Gap

With exclusive Titan radial sidewings, the opening between sidewings and apron is greatly reduced. Tight tolerance is maintained regardless of direction of belt flex. Aprons are available in plain, perforated or pimped styles. All belts delivered from stock components. Detail drawings on request.



2 1/2" Pitch Belts

Titan hinged steel belt was developed to handle stampings, metal scrap, paper scrap, chips, turnings, castings and parts, plus numerous other materials. The standard 2 1/2" pitch belt is interchangeable with other conveyor or belt manufacturers. All parts on standard belts are available from stock. Standard profile and low profile sidewings are available. Belt widths from 4" to 48" in increments of 2".

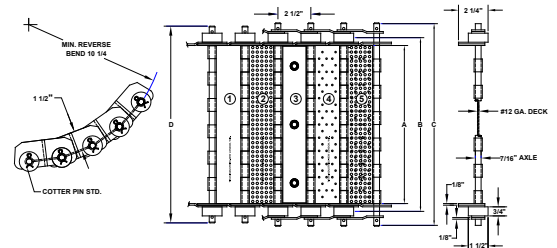
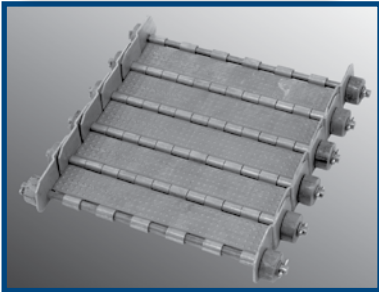

**Chain Pull: 1200#
2500# (with side bar)**

4" Pitch Belts

The Titan 4" pitch hinged steel belt contains the 2" diameter flanged roller as a standard feature - without additional cost. The flanged rollers aid belt tracking. When Titan belts are used to replace those of other manufacturers, Titan can supply those belts with regular flat face rollers if needed. If extra impact absorption is needed for rough loading conditions, Titan will add reinforcement bars to the 10 gauge apron.

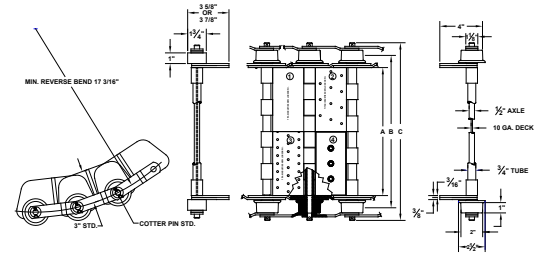
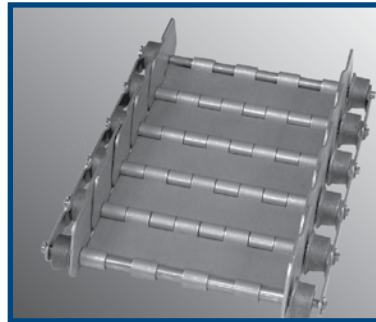

Chain Pull: 6000#

**Belt Styles: 1-Plain, 2-Perforated, 3-Double Perforated
4-Impact Bar**

6" Pitch Belts

A genuine heavy-duty belt equal to the demands of sophisticated, automatic scrap handling systems, Belts feature full 1/4" thick apron and sidewings, a 15/16" tube with a 3/4" through pin, and die formed hinges which eliminate the usual weld bead. Belts also have 3" diameter single flange cast iron rollers with hardened bushings. Titan will also supply them with flat face roller. Titan 6" pitch belts are available in dimpled, plain or perforated styles.

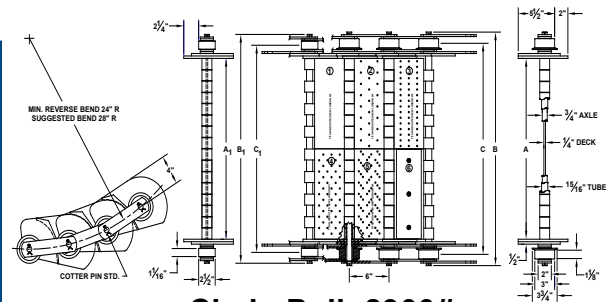
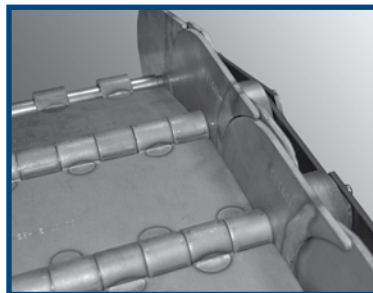

Chain Pull: 8900#

**Belt Styles: 1-Plain, 2-Perforated, 3-Double Perforated
4-Pimped, 5-Pimped & Perforated, 6- Impact Bar**

AUTHORIZED DISTRIBUTOR