



Industrial Conveyor Specialists

**MODEL 104 Drum Motor**  
**SLIDER BED CONVEYOR**



The drum motor Model 104 is a one-component conveyor drive where the motor, gear reducer and all moving parts are enclosed inside the drum. The motor and gear reducer operate in a sealed oil bath ensuring proper lubrication and cooling. The compact design of the drum motor provides space savings, efficiency and reliability when compared to conventional drive packages.

**BENEFITS**

- No external moving parts increases operator safety
- Compact single unit design enhances space utilization
- 96% mechanical efficiency reduces energy costs
- No maintenance reduces operating costs

As with all Titan Conveyors, there is an endless list of options to customize your conveyor.

**MODEL 104 SLIDER BED CONVEYORS SPECIFICATIONS**

|  | <b>STANDARD</b>                        | <b>OPTIONS</b>   |
|--|--|--|
| <b>Belt Widths</b>   | 4" thru 48"                            | Specify  |
| <b>Lengths</b>   | 2' to 10'                              | 3' to 40'  |
| <b>Belt Type</b>   | PVC 120 Black                          | Rough top, V-guide on bottom, Food Grade or belt to suit application |
| <b>Drive</b>   | 1/2 HP 230V 3PH Motorized Drive Pulley | 110V, 220V<br>Stainless - many options available                     |
| <b>Frame</b>   | 5 1/2" deep formed 12 ga.              |  |
| <b>OPTIONAL</b>  |  |  |
| H.P., speed, fixed or variable speed, belt type, siderails, casters, galvanized, stainless, transfer roller, special paint, belt scraper, food grade, many other options available, consult factory representative |  |  |

# MODEL 104 Drum Motor

## SLIDER BED BELT

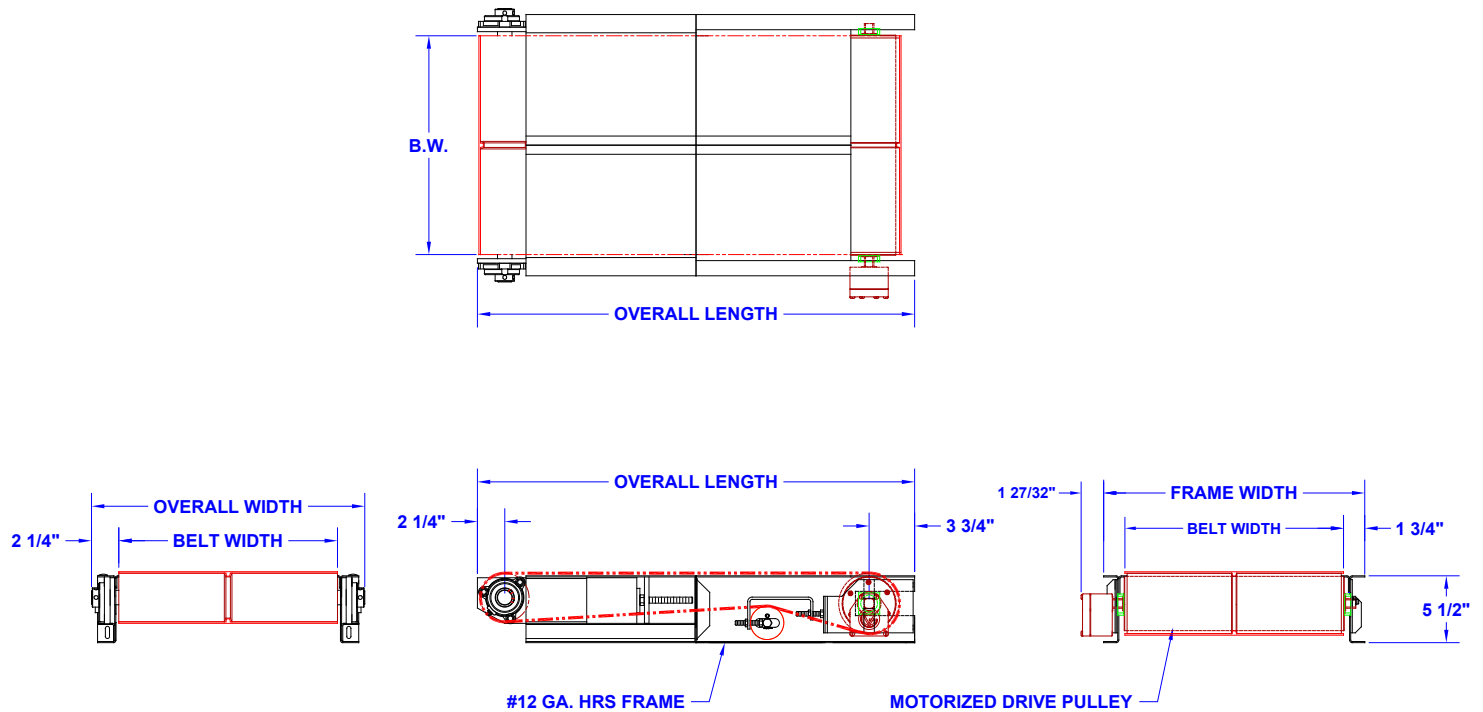

### V-Groove Pulleys Shown

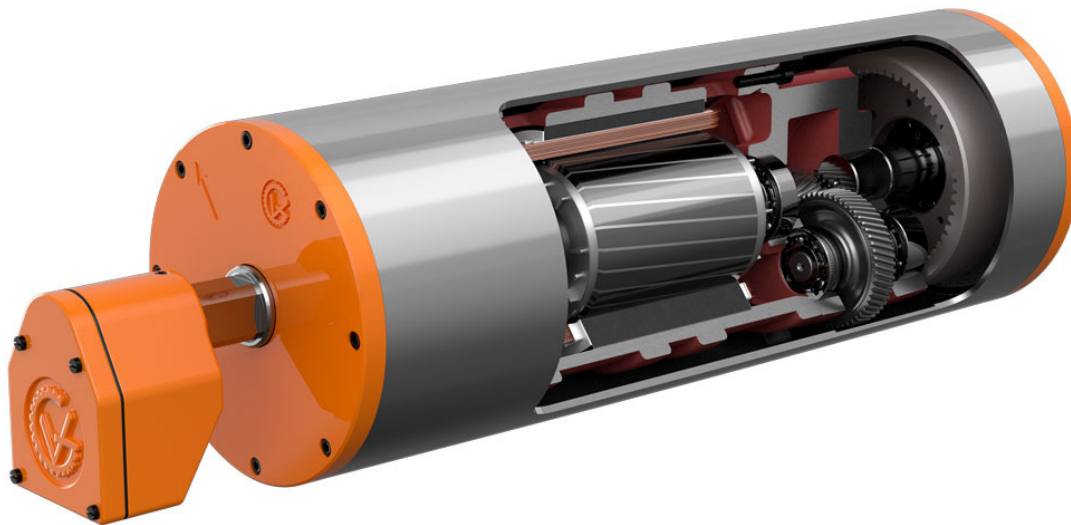

The predominant drum motor advantage over conventional systems is efficiency, this equals a positive return on investment. With a total operating cost lower than a conventional drive systems, the drum motor will pay for itself. This includes design, engineering and installation time. The return on investment is achieved through electrical and mechanical efficiencies. Lower operating costs equal increased profits.



Website: [www.titanconveyors.com](http://www.titanconveyors.com) • Email: [sales@titanconveyors.com](mailto:sales@titanconveyors.com)  
735 Industrial Loop Road • New London, WI 54961-9612  
920-982-6600 • Fax: 920-982-7750 • Toll Free: 800-558-3616