



Replacement Parts RFQ for Model 110 - V-Guide Slider Bed Belt Conveyor

Note: Chrome Browser will not email -Download form and attach to an email to: sales@titanconveyors.com

Company

Phone

Contact

Conveyor

E-mail

Serial Number

To Request a Quote for Spare Parts - Fill in the Information below & Quantity of each Part & Click on the Email Button

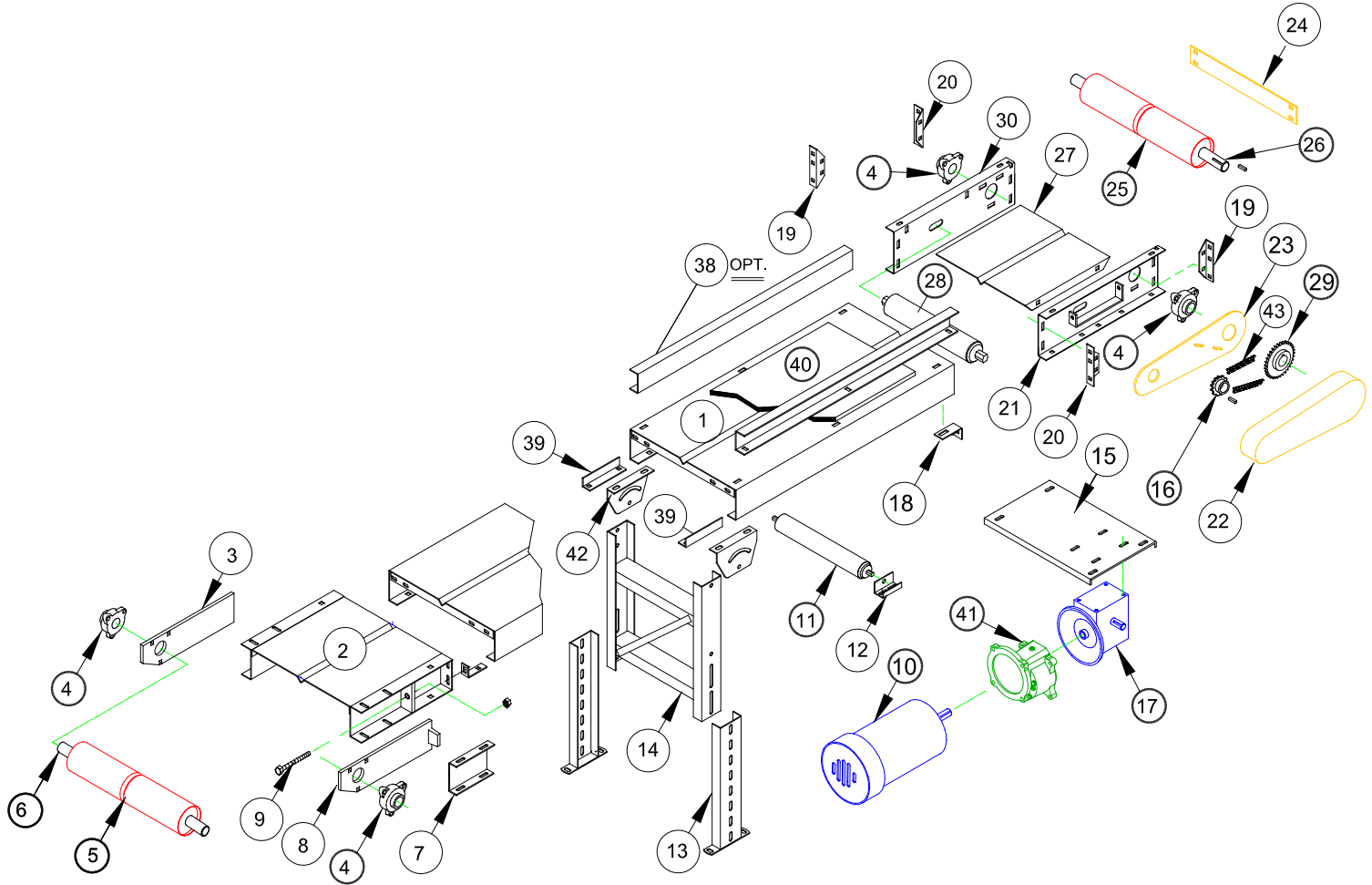

• Recommended spare parts to be stocked at your location

Part
Number - Description - Qty.

- 4. • 3 BOLT FLANGE BEARING
- 5. • V-GUIDE TAIL PULLEY
- 6. • TAIL PULLEY SHAFT
- 10. • MOTOR
- 11. • RETURN ROLLER
- 16. • DRIVE SPROCKET
- 17. • REDUCER
- 25. • V-GUIDE DRIVE PULLEY
- 26. • DRIVE PULLEY SHAFT
- 28. • SNUB ROLLER
- 29. • DRIVEN SPROCKET
- 40. • BELT
- 41. • RATIO MULTIPLIER
- 43. • ROLLER CHAIN

Other Parts

- 1. INTERMEDIATE FRAME
- 2. INFEED FRAME
- 3. TAKE-UP BAR L/H
- 7. RETAINER CHANNEL
- 8. TAKE-UP BAR R/H
- 9. TAKE-UP BOLT
- 12. RETURN ROLLER BRACKET
- 13. LOWER SUPPORT
- 14. UPPER SUPPORT
- 15. MOTOR BASE
- 18. HEAD SECTION SPLICE PLATE
- 19. CONNECTOR BRACKET L/H
- 20. CONNECTOR BRACKET R/H
- 21. HEAD PLATE R/H

- 22. GUARD
- 23. GUARD BACK
- 24. DRIVE SPREADER
- 27. DRIVE SECTION DECK
- 30. HEAD PLATE L/H
- 31. SIDEMOUNT DR. MOTOR BASE
- 32. SIDEMOUNT DRIVE GUARD
- 33. TOP MT. DR. ADAPTOR PLT. R/H
- 34. TOP MT. DR. ADAPTOR PLT. L/H
- 35. GUARD BACK TOP MT. DRIVE
- 36. GUARD TOP MT. DRIVE
- 37. LOWER GUARD TOP MT. DRIVE
- 38. SIDERAIL
- 39. SUPPORT SPLICE ANGLE
- 42. SMILE BRACKET

To Request a Quote for Spare Parts - Fill in the Information below & Quantity of each Part & Click on the Email Button

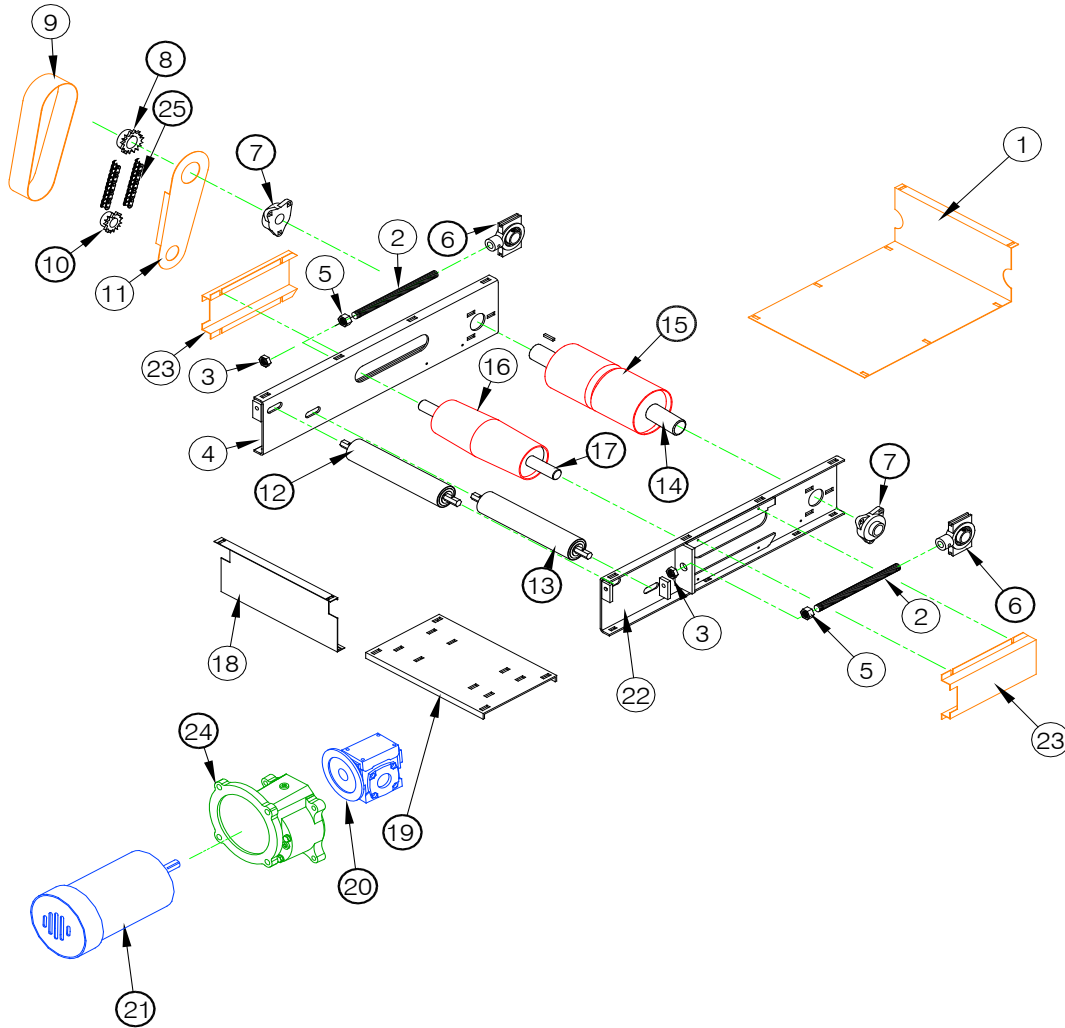

• Recommended spare parts to be stocked at your location

Part Number - Description	Qty.
6. • TAKE-UP BEARING 1 3/16" DIA.	
7. • 3-BOLT FLANGE BEARING	
8. • DRIVEN SPROCKET	
10. • DRIVE SPROCKET	
12. • SNUB ROLLER	
13. • SNUB ROLLER	
14. • DRIVE SHAFT	
15. • V-GUIDE DRIVE PULLEY	
16. • TAKE-UP PULLEY	
17. • TAKE-UP SHAFT	
20. • REDUCER	
21. • MOTOR	
24. • RATIO MULTIPLIER	
25. • ROLLER CHAIN	

Other Parts

- 1. LARGE GUARD C.D. & T.U.
- 2. THREADED ROD
- 3. HEX JAM NUT
- 4. C.D. & T.U. PLATE LH
- 5. HEX NUT
- 9. GUARD FRONT
- 11. GUARD BACK
- 18. SMALL GUARD C.D. & T.U.
- 19. MOTOR BASE
- 22. C.D. & T.U. PLATE R/H
- 23. TAKE-UP GUARD