

MODEL 118

TROUGHED BELT CONVEYOR



The **Model 118 troughed belt conveyor** is designed as a cost competitive medium duty bulk conveyor. The standard 4" deep formed 12 gauge frame allows for reduced total weight and yet the rigidity needed for medium duty applications. Excellent design for transporting loose parts or bulk materials. Bottom, top or center drive available.

MODEL 118 SLIDER BED TROUGH CONVEYORS		
	Standard	Options
Belt Widths	6" to 72"	Other widths available
Lengths	5' min. to 40' max.	3' min. to 50' max.
Belt Type	PVC 120 Black	Food grade
Drive	1/2 H.P. 230/460/3/60	3/4, 1, 1-1/2, 2 HP, 115/230/1/60, TEFC, washdown, severe duty, inverter duty, brake motor
Drive Pulley	8" dia. crowned rubber lagged - 4" tail pulley	6" tail pulley for widths over 54"
Frame	4" deep formed 12 g.a.	
OPTIONAL		
H.P., drive location, speed, fixed or variable speed, controls, belt widths, belt type, center drive & take-up, galvanized, stainless, siderails, supports, casters, other belt types, siderail skirting, belt scrapper, machined and balanced pulleys for high speed, discharge housing, e-stop with pull cord, special paint		
Many other options available, consult factory representative		

NOTE: Specifications subject to change without notice

MODEL 118

TROUGHED BELT CONVEYOR

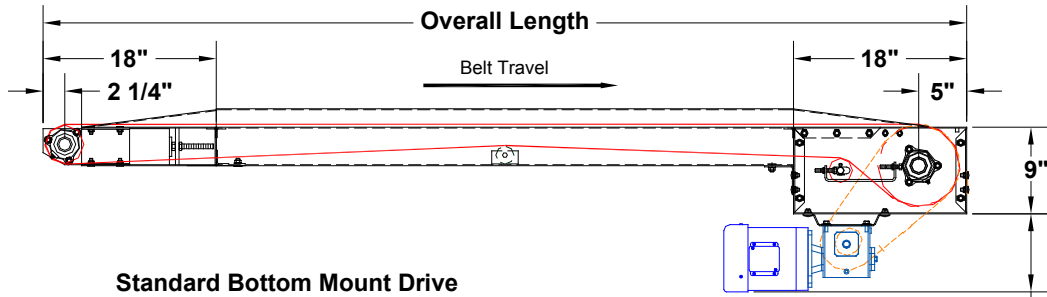

Standard Bottom Mount Drive

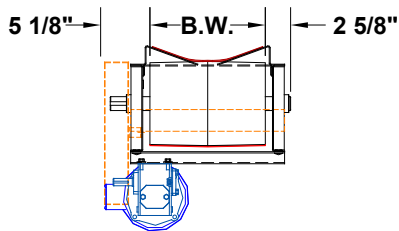

Standard Drive Cross Section

- BMQ #815 - 8 1/8"
- BMQ #818 - 7 3/8"
- BMQ #821 - 7 7/8"
- BMQ #824 - 8 15/32"
- BMQ #826 - 9 5/32"

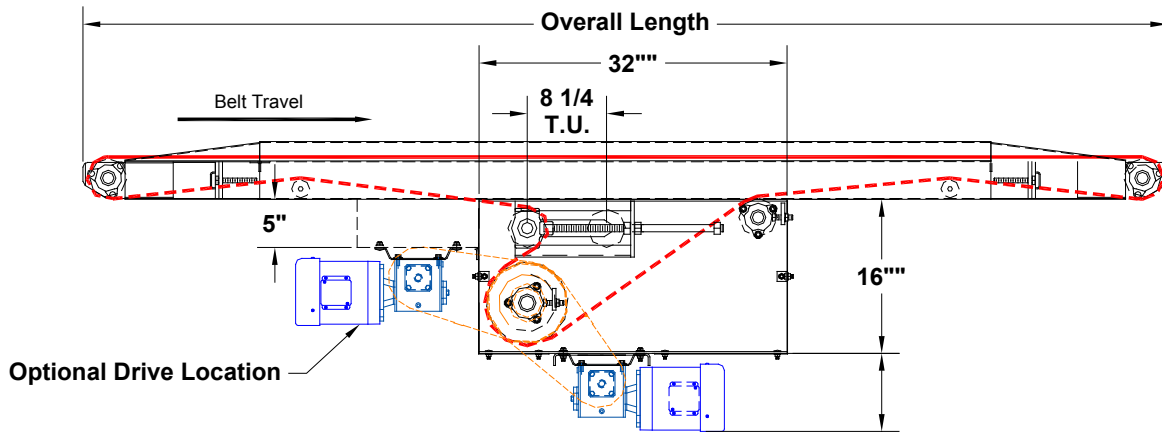

Optional Drive Location

Standard Center Drive & Take-Up

- BMQ #815 - 8 1/8"
- BMQ #818 - 7 3/8"
- BMQ #821 - 7 7/8"
- BMQ #824 - 8 15/32"
- BMQ #826 - 9 5/32"

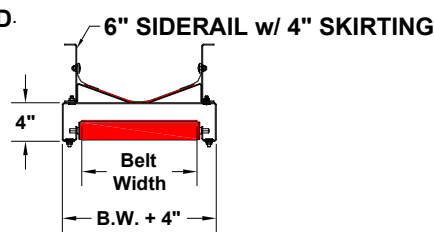
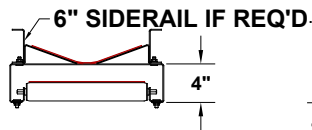

735 Industrial Loop Road • New London, WI 54961-9612
 • 920-982-6600 • Fax 920-982-7750 • Toll Free 800-558-3616
 Website: www.titanconveyors.com • Email: sales@titanconveyors.com

