

# MODEL 310 PARTS CONVEYOR

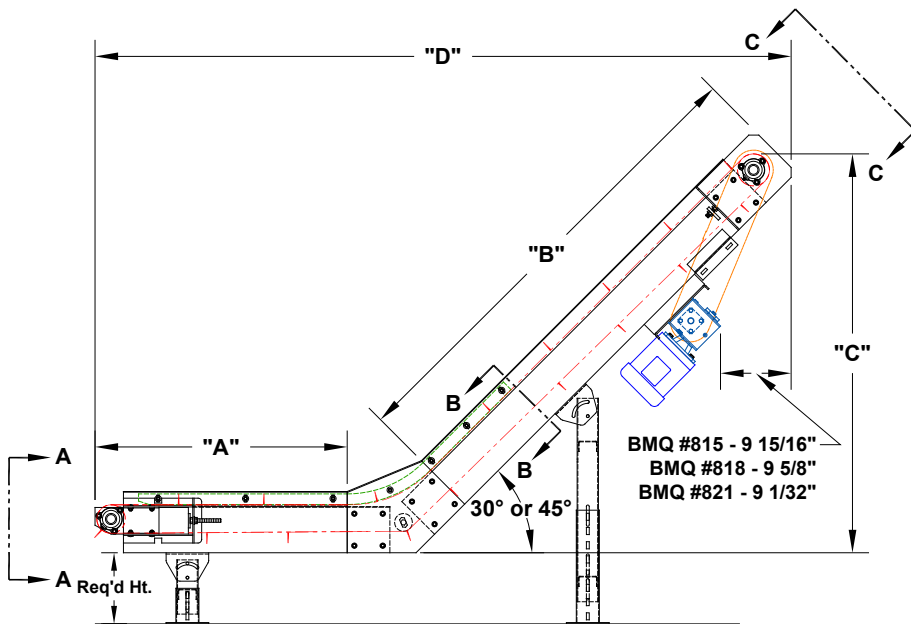
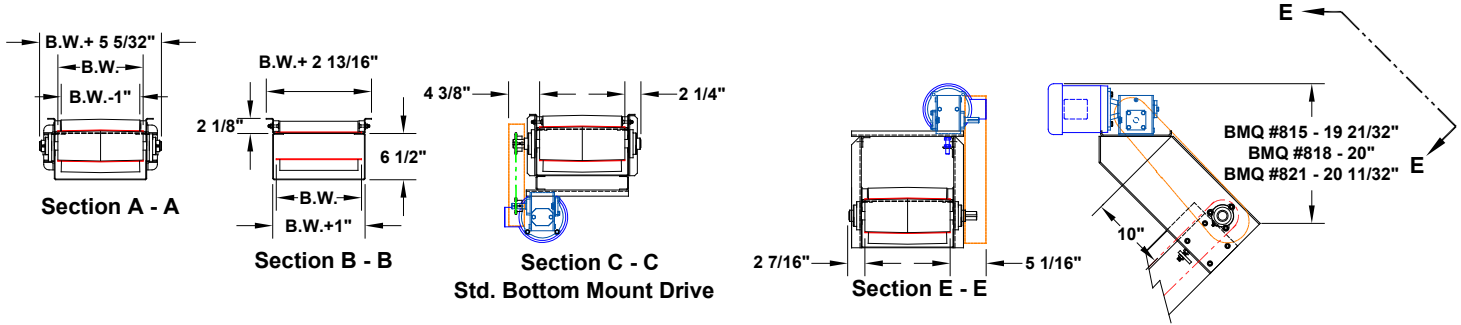

30°		"D" O.A.L.			
		"B" (Incline)			
"A" INFEED	24"	36"	48"	60"	72"
	36"	71	81.5	92	102.5
	48"	83	93.5	104	114.5
	60"	95	105.5	116	126.5
"C" Hgt.		26	32	38	44

45°		"D" O.A.L.			
		"B" (Incline)			
"A" INFEED	24"	36"	48"	60"	72"
	36"	65.5	74	82.5	91
	48"	77.5	86	94.5	103
	60"	89.5	98	106.5	115
"C" Hgt.		34.7	43.2	51.7	60.2

Optional Infeed Hopper

