

TITANTM
CONVEYORS

Industrial Conveyor Specialists

Paper Industry Conveyors

For Handling

- Bales
- Roll
- Broke



**Extreme Duty
Proven Reliability
Low Maintenance
Quick Delivery**

**The TITAN Experience -
*Expect More***

735 Industrial Loop Road
New London, WI 54961-2600

Phone: (920) 982-6600

Fax: (920) 982-7750

Toll Free: 1-800-558-3616

Website: www.titanconveyors.com

Email: sales@titanconveyors.com

Since 1981

Bale Handling

6" Pitch Hinged Steel Belt Conveyor

- 12,000 load capacity
- Up to 72" Belt Width
- For the toughest handling
- Extra heavy duty 1/4" apron with 4" high 1/4" side wing
- 3/4" diameter axle with heavy duty bushing
- 3" single flange thru hardened metal roller



6" Pitch Chain Edge Belt Conveyor

- 12,000# load capacity
- Up to 72" belt width
- Sandwich a heavy duty PVC belt bottom stabilizer bar & square tube welded cleat for strength & performance
- Load is carried on 3" flange rollers and UHMW wear strips to provide large capacity with minimum horsepower requirements

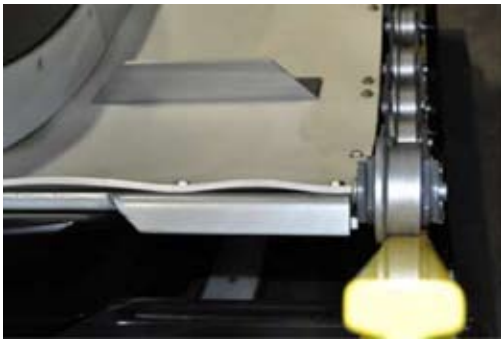

What Makes Titan Better?

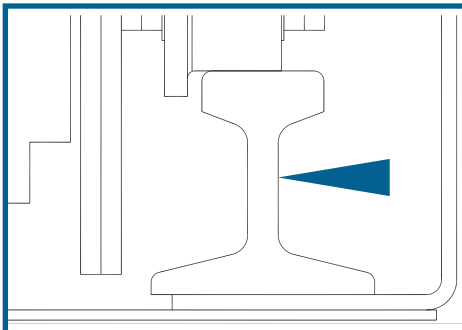

1. H.D. 25# rail track reduces wear factors and improves conveyor integrity.

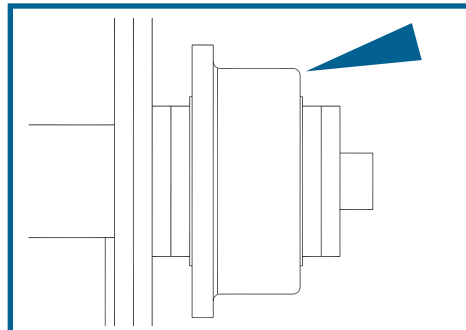

2. 3" diameter bushed single flanged rollers. Sintered metal composition allows for closer machining tolerance and improves wear factors.

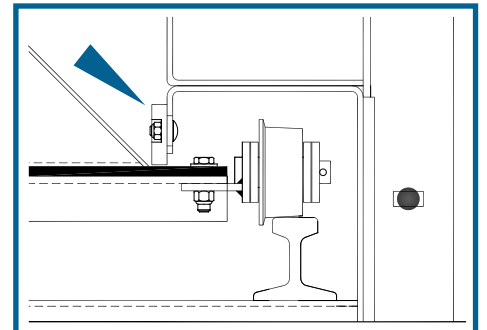

4. H.D. UHMW strips prevent product leakage, maintain clearance tolerance between belt and side rail.

Virgin Bale Handling

Multi-Strand Chain Conveyor

- Designed for movement of dense product
- Ideal for bale transfer and de-wiring
- Accommodates other control or process devices
- Integrates easily in systems with other conveyors
- Distributes product load evenly



Roll Handling

Chain Driven Live Roller Conveyor

- Ideal for rolls, pallets, skids
- Extreme heavy duty use up to 5,000 lb/ft capacity total load up to 27,000 lbs.
- Accumulation, lifts, centering
- Transfers, stops, jack plates for side or end load/unload
- Curves, turntables
- Can be mounted on automated guided carts



Slat Conveyor

- Extra heavy duty 7 gauge frame
- 4" or 6" pitch
- formed V, lugs or fixtures available for roll control
- Accumulation, side loading & unloading available
- Ideal for mounting in a pit flush with the floor



Broke Handling



Slider Bed Conveyors



- Economical choice
- Models available for all widths and load capacity
- Wide range of belt types dependent upon the application
- Above grade, pit mounted or mounted to your machine
- Rugged industrial design
- Square head and tail for system assembly
- Grease sealed bearings and screw take-up
- Many side rail options available

Roller Bed Conveyor



*Designed for years of
maintenance free
operation in hostile
environments*



AUTHORIZED DISTRIBUTOR

TITAN[™]
CONVEYORS

735 Industrial Loop Road
New London, WI 54961-2600
Phone: (920) 982-6600
Fax: (920) 982-7750
Toll Free: 1-800-558-3616
Website: www.titanconveyors.com
Email: sales@titanconveyors.com